

**TIANJIN HIGHSEN TRADING**  
COLD ROLLED ELECTRICAL STEEL



▪ CRGO ▪ CRNGO



# ABOUT HIGHSEN



Tianjin Highsen Trading Co.,Ltd. is a global all-in-one steel solutions provider with **ISO 9001:2015** certification



**80+** clients with sales coverage in over **30+** countries



**40+** steel mills world wide



**200+** thousand tonnes sales volume as of Dec 31 2023



**\$15+** million net sales as of Dec 31 2023

# CERTIFICATION

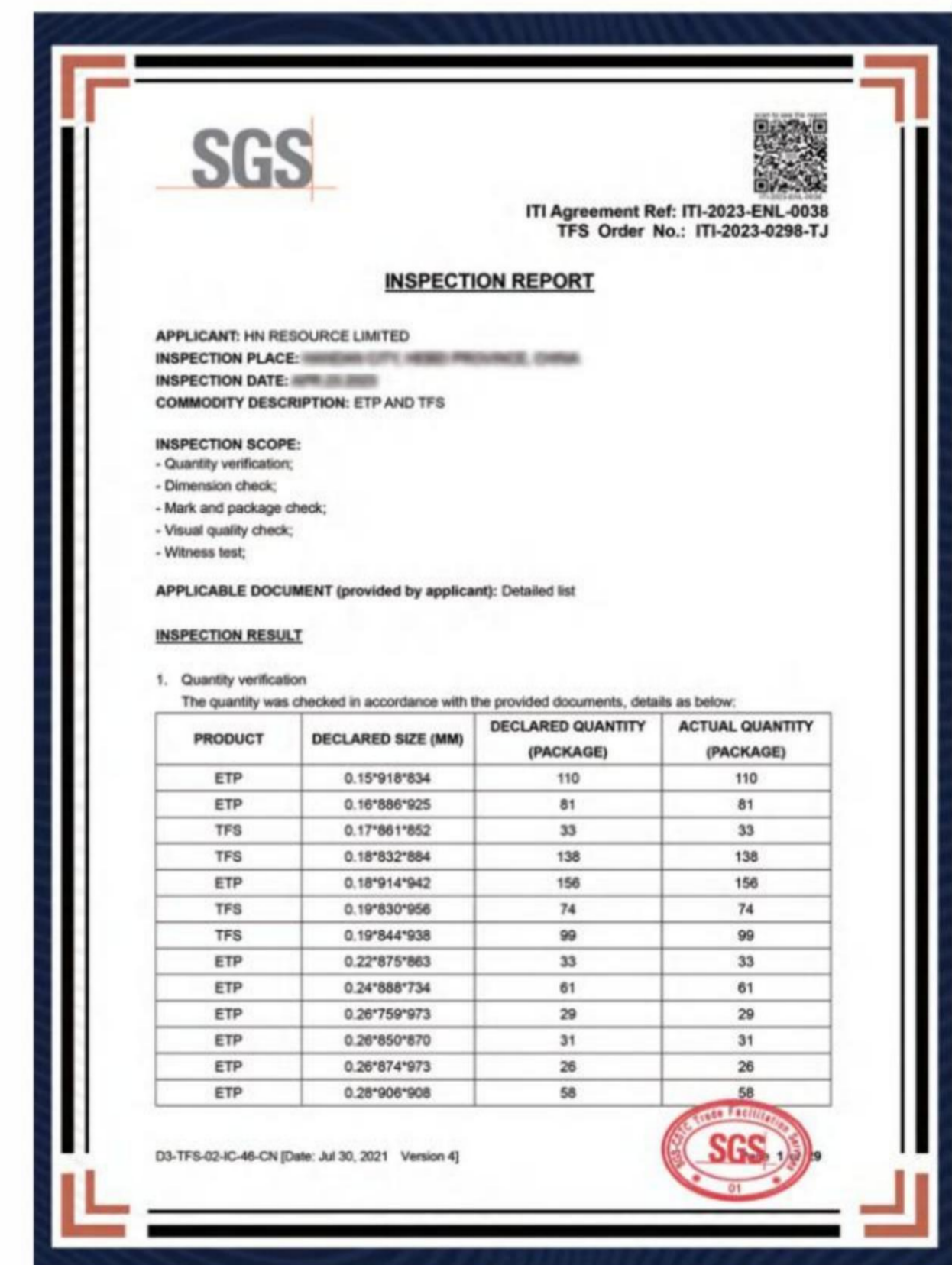
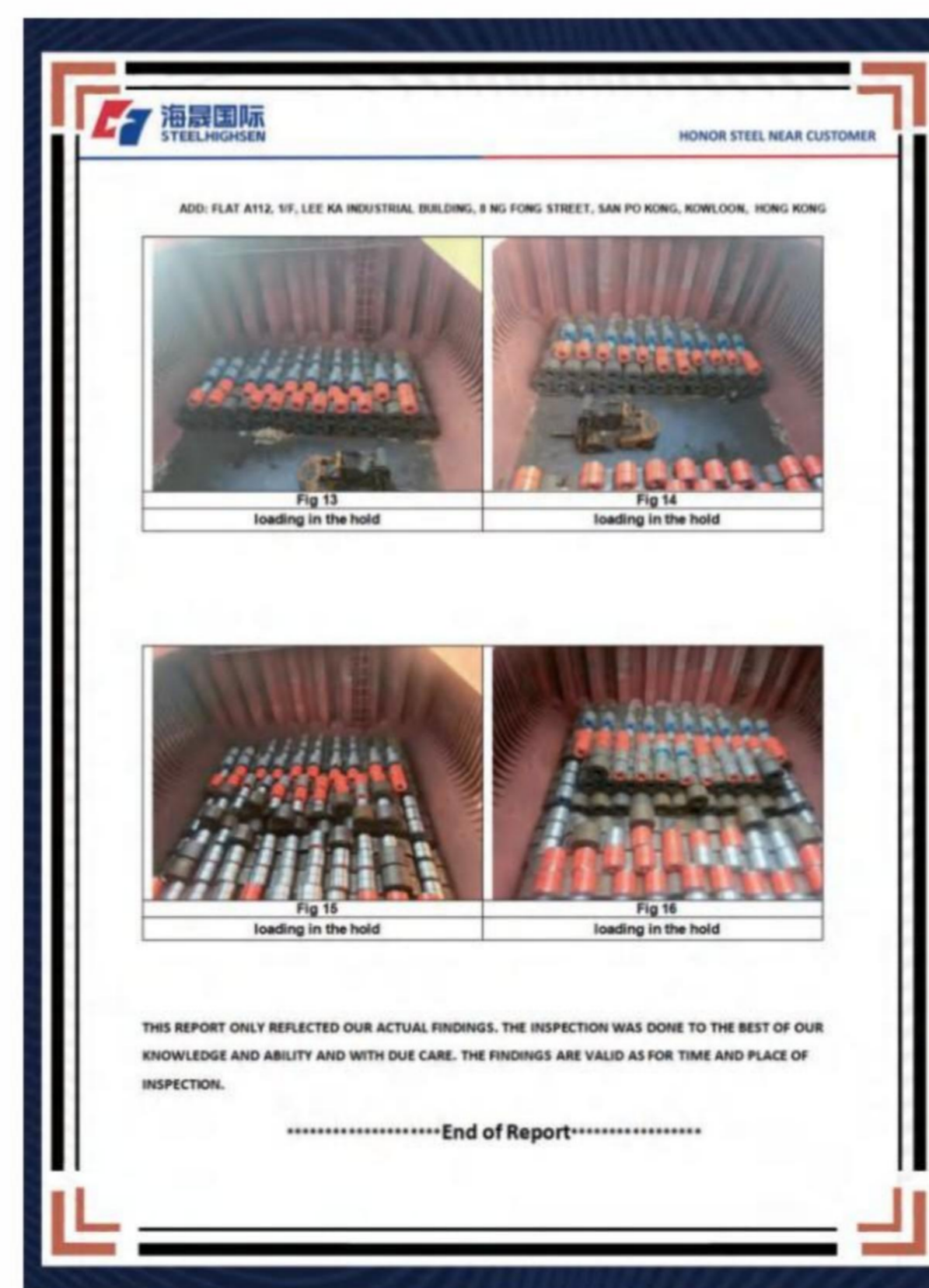



# CONTENTS

## 01 CRGO

01 - 05

Production Flow

Application

Major Standard

Regular Grade

## 02 CRNGO

06 - 11

Production Flow

Application

Major Standard

Regular Grade

## 03 WHY US

12 - 16

Suppliers

Package

Shipment

MTC





# CRGO

## Cold Rolled Grain Oriented Steel



The easy magnetization direction of grain-oriented electrical steel is parallel to the rolling direction. It has excellent magnetic properties such as low iron loss, high magnetic permeability, and low magnetostriction.



CRGO is widely used in transformers, reactors, mutual inductors, motors and other industries. Meanwhile it can obtain lower core loss by domain refinement treatment.

## Production Flow

### Common Grain Oriented Electrical Steel

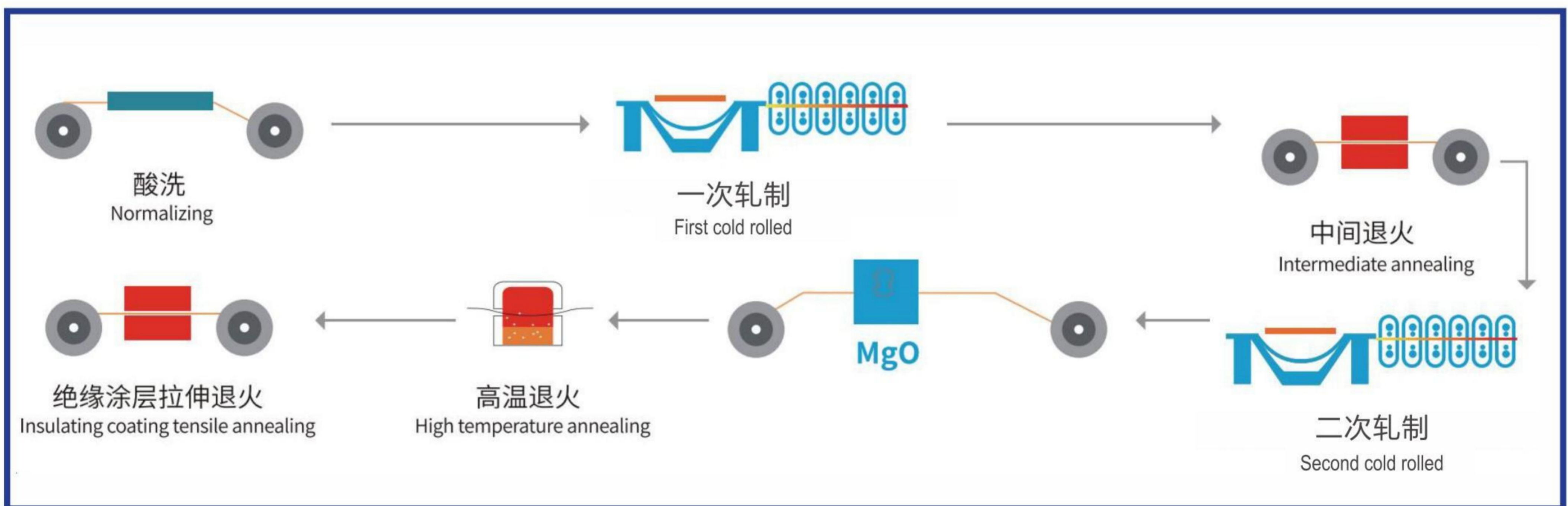

### High Permeability Electrical Steel

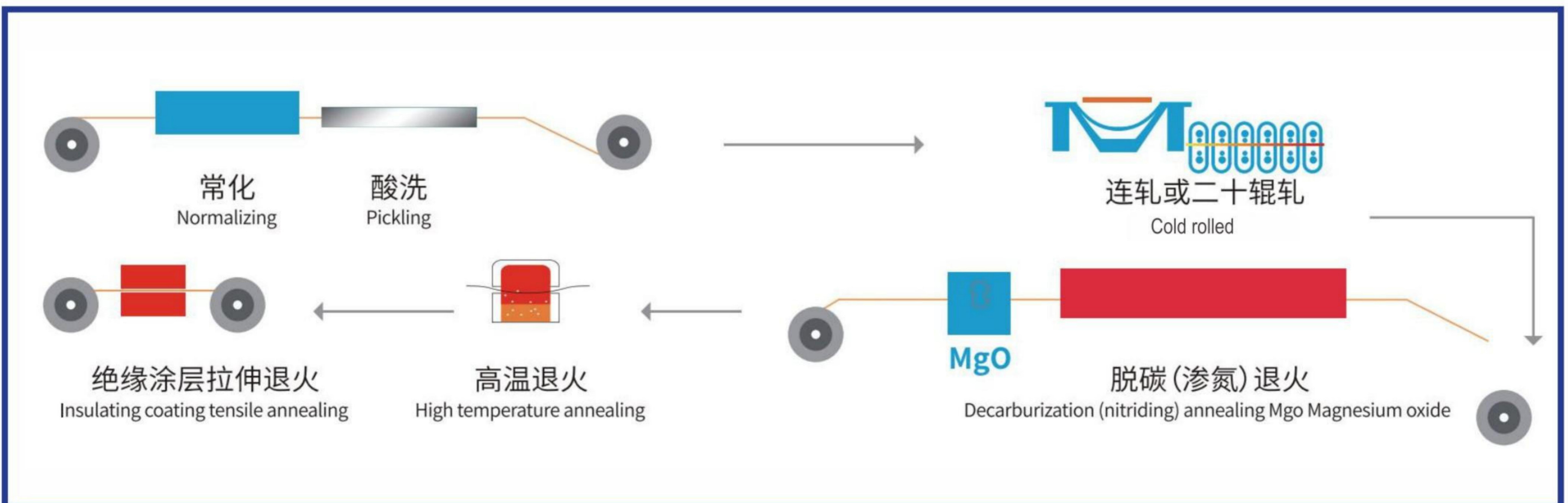



# Application

Varieties	Common Type	High Induction Type	Domain Refined High Induction Type
Large Motors	★	★	
Large Transformers	★	★	★
Medium and Small Transformers	★	★	★
Distributing Transformer	★	★	
Voltage Regulators	★	★	
Reactor and Magnetic	★	★	★
IF Transformers		★	
Mutual Inductors	★	★	
TV Transformers	★	★	
Radio Transformers	★	★	
Radio Broadcast Transformers		★	

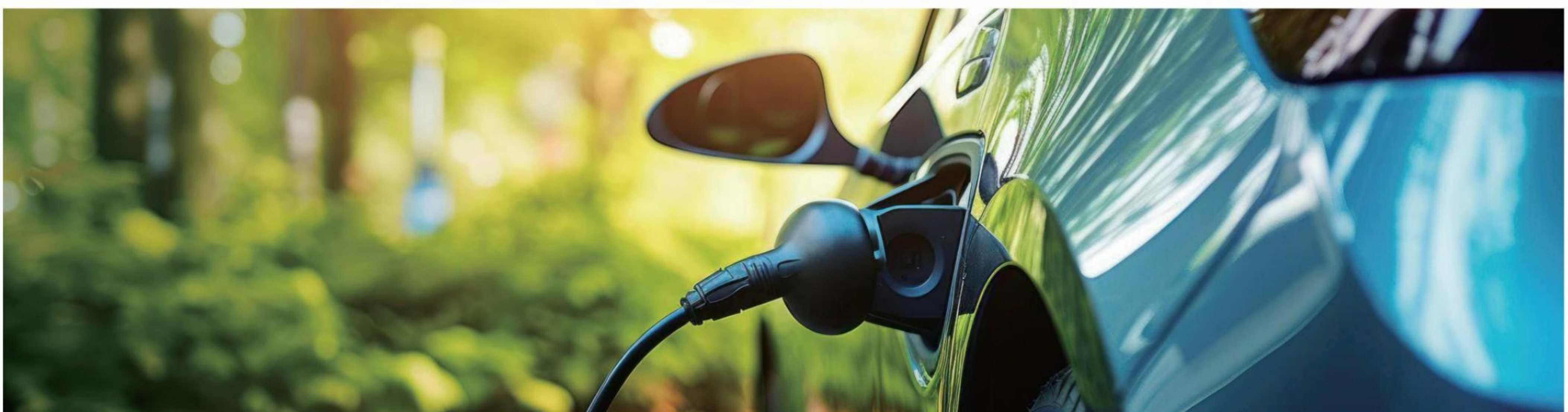



# Major Standard

Thickness	POSCO(2006) w/kg,	JIS C 2553 (2006) w/kg,	ASTM (1999) w/kg,	EN 10107 (1995) w/kg,	IEC 60404 (2008) w/kg,	BIS 3024 (2006) w/kg,
	P1.7/50	P1.7/50	P1.7/50	P1.7/50	P1.7/50	P1.7/50
0.18	-	-	M2, 1.00	-	-	-
	23PHD085 / 0.85	23R085 / 0.85	-	-	M85-23P5 / 0.85	23HP85d / 0.85
0.23	23PHD090 / 0.90	-	-	-	M90-23P5 / 0.90	M105 - 30PS / 1.05
	23PH090 / 0.90	23P090 / 0.90	23Q054 / 1.19	-	-	M130 -30S5 / 1.30
	23PH095 / 0.95	23P095 / 0.95	-	M100-23P / 1.00	M95-23P5 / 0.95	M145-35S5 / 1.45
	23PH100 / 1.00	23P100 / 1.00	23P060 / 1.32	-	M100-23P5 / 1.00	-
	23CG120 / 1.20	-	-	-	-	-
0.27	27PHD090 / 0.90	27R090 / 0.90	-	-	M90-27P5 / 0.90	27HP90d / 0.90
	27PHD095 / 0.95	-	-	-	M95-27P5 / 0.95	27HP95d / 0.95
	27PH095 / 0.95	-	-	-	-	27HP95 / 0.95
	27PH100 / 1.00	27P100 / 1.00	27P066 / 1.46	M103-27 / 1.03	M100-27P5 / 1.00	27HP100 / 1.00
	27PH110 / 1.10	-	-	-	M110-27P5 / 1.10	27HP110 / 1.10
	27PG130 / 1.30	27G130 / 1.30	-	-	M130-27S5 / 1.30	27CG130 / 1.30
0.30	30PH100 / 1.00	-	-	M105-30P / 1.05	-	-
	30PH105 / 1.05	30P105 / 1.05	-	-	M105 - 30PS / 1.05	30HP105 / 1.05
	30PG130 / 1.30	30G130 / 1.30	-	M117-30P / 1.17	M130 -30S5 / 1.30	30CG130 / 1.30
0.35	35PG145 / 1.45	35G145 / 1.45	-	M150-35S / 1.50	M145-35S5 / 1.45	35CG145 / 1.45





# Regular Grade

Electromagnetic performance standard ordinary oriented silicon steel Q series

Grade	Thickness	Density	Max Iron Loss	Min Magnetic Induction
	(mm)	(KG/dm <sup>3</sup> )	(w/kg)	
23Q110	0.23	7.65	1.10	1.80
23Q120			1.20	
27Q110	0.27	7.65	1.10	1.80
27Q120			1.20	
27Q130			1.30	
30Q120	0.30	7.65	1.20	1.80
30Q130			1.30	
30Q140			1.40	
35Q135	0.35	7.65	1.35	1.80
35Q145			1.45	
35Q155			1.55	

High magnetic orientation silicon steel QG series

Grade	Thickness	Density	Max Iron Loss	Min Magnetic Induction
	(mm)	(kg/dm <sup>3</sup> )	(w/kg)	
23QG85	0.23	7.65	0.85	1.87
23QG90			0.90	
23QG95			0.95	
23QG100			1.00	
27QG90	0.27	7.65	0.90	1.88
27QG95			0.95	
27QG100			1.00	
30QG100	0.30	7.65	1.00	1.88
30QG105			1.05	
30QG110			1.10	
30QG120			1.20	
35QG115	0.35	7.65	1.15	1.88
35QG125			1.25	
35QG135			1.35	



Domain thinning high magnetic orientation silicon steel QGD series

Grade	Thickness	Density	Max Iron Loss	Min Magnetic Induction
	(mm)	(kg/dm <sup>3</sup> )	(w/kg)	
23R080	0.23	7.65	0.80	1.87
23R085			0.85	
23R090			0.90	
27R085	0.27	7.65	0.85	1.87
27R090			0.90	
27R095			0.95	

## Note



Test according to GB/T3655-2008(Q series and QG series),GB/T13789-2008 (QGD series).



Q series and QG series samples were carried out along the rolling direction and subjected to stress relief annealing treatment at 800 °C for 2 hours after magnetic properties were tested.



P1750 represents the core loss per kg sample when the maximum magnetic induction intensity is 1.7T and the frequency is 50Hz.



We have cooperative factories for non-lasered CRGO.





# CRNGO

## Cold Rolled Non-Grain Oriented Steel



Cold rolled non-grain oriented steel is normally called CRNGO, NGO, NOES. The grain direction of non-oriented silicon steel is randomly distributed, and the electromagnetic properties are uniform, widely used in the field of motor industry.

## Production Flow

### Low and Medium Grade Non-oriented Electrical Steel

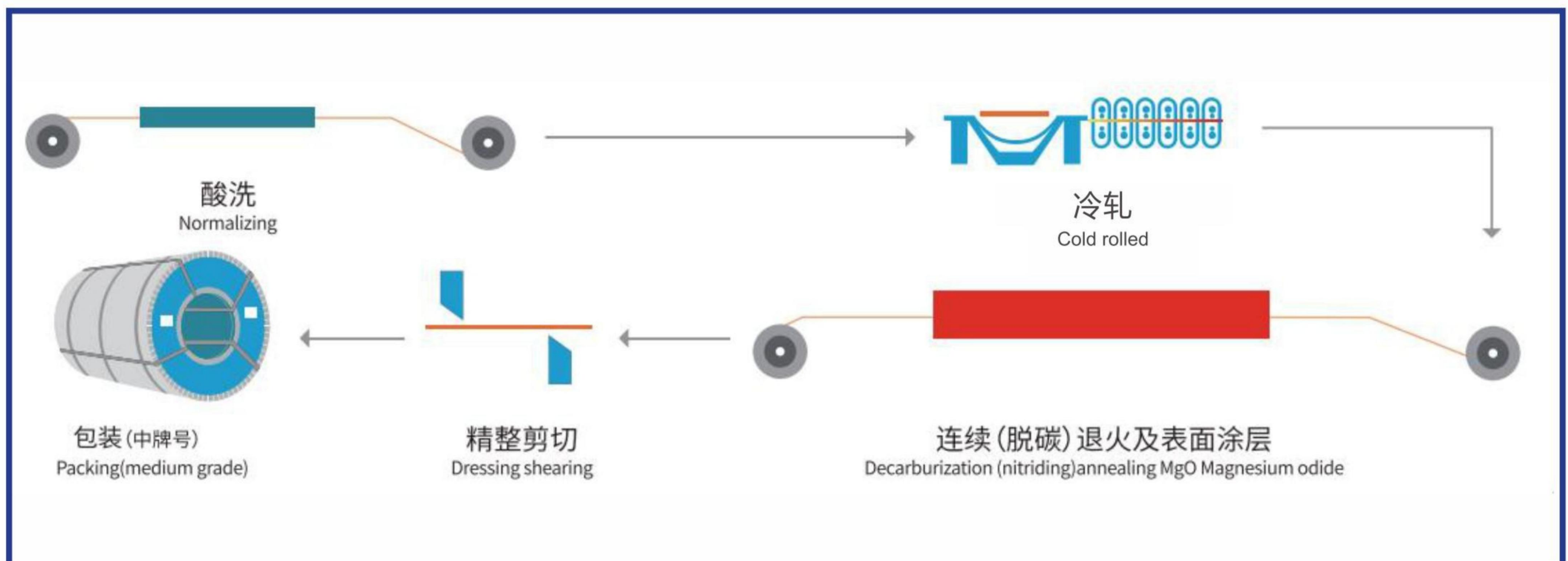

### High Grade Non-oriented Electrical Steel Non-oriented Electrical Steel for New Energy Vehicles

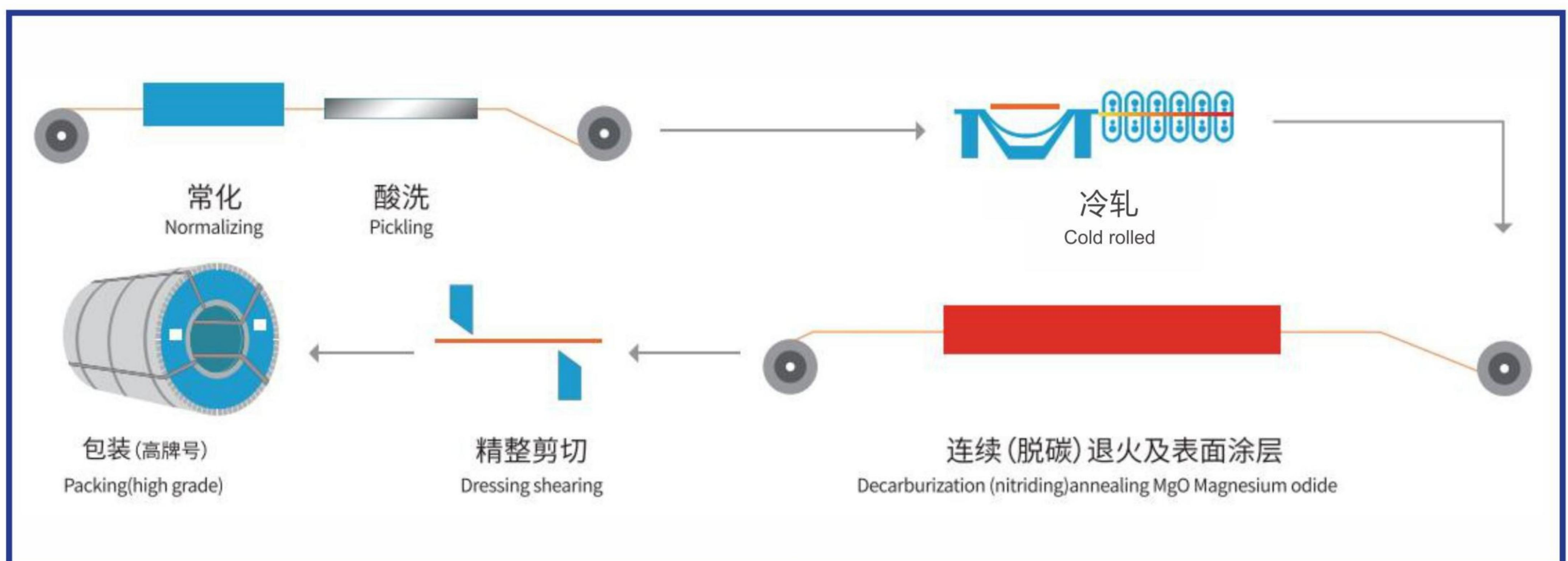



# Application

Application	General Class		High- Efficiency Class		Annealing	Intermediate Frequency Thin Strip
	High-Grade	Medium & Low Grade	High-Grade	Medium & Low Grade		
Large Motor	★					
Medium and Small Motor	★	★	★			
Compressor Motor	★	★	★	★	★	
General Motor	★	★	★	★	★	★
Small Precision Motor	★	★	★		★	★
Electric Vehicle Motor	★					
High Frequency Working Motor	★	★				★
Small Power Transformer	★	★	★	★	★	
Power Switch	★					
Welding Motor		★	★	★		
Voltage Regulator	★	★		★	★	
Magnetic Seals	★	★				
Accelerator Electromagnet		★	★			
Reactors and Magnetic Amplifier	★					

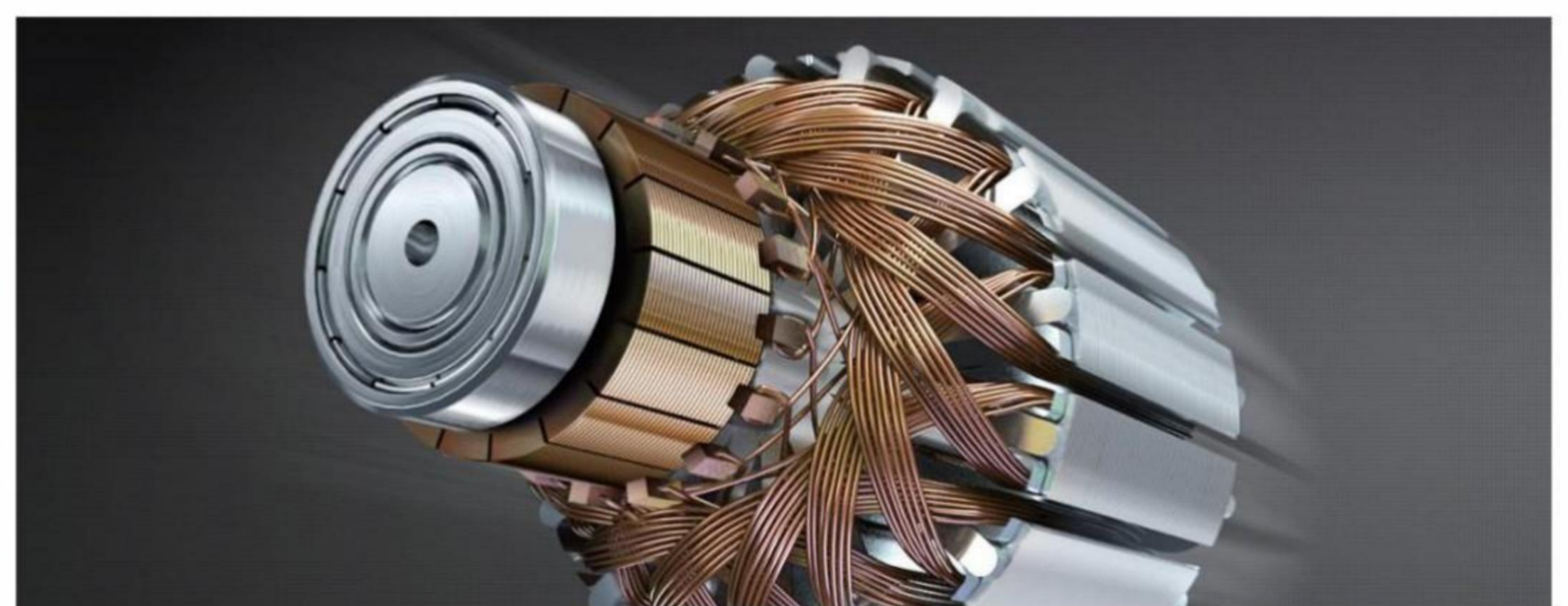



# Major Standard

Type	Thickness	Shougang	NSC	JFE	TKS	POSCO	NI&Sco	AK	
	(mm)								
General Series	0.35	35SW230	35H230	35JN230	M235-35A	35PN230	-	-	
		35SW250	35H250	35JN250	M250-35A	35PN250	2413	M-15	
		35SW270	35H270	35JN270	M270-35A	35PN270	2412	M-19	
		35SW300	35H300	35JN300	M300-35A	35PN300	2411	M-22/ M-27	
		35SW360	35H360	35JN360	-	35PN360	-	-	
		35SW440	35H440	35JN440	-	35PN455	-	-	
		35SW550	-	-	-	35PN560	-	-	
	0.50	50SW230	50H230	50JN230	M230-50A	5DPN230	-	-	
		50SW250	50H250	50JN250	M250-50A	50PN250	-	-	
		50SW270	50H270	50JN270	M270-50A	50PN270	2414		
		50SW290	50H290	50JN290	M290-50A	50PN290	2413	M-15	
		50SW310	50H310	50JN310	M310-50A	50PN310	2412	M-19	
		50SW350	50H350	50JN350	M350-50A	50PN350	-	M-22	
		50SW400	-	-	M400-65A	50PN400	-	M-27/ M-36	
		50SW470	50H470	50JN470	M470-50A	50PN445	2214	-	
		50SW600	50H600	50JN600	M600-50A	50PN595	2212	-	
		50SW700	50H700	50JN700	M700-50A	50PN760		M-47	
		50SW800	50H800	50JN800	M800-50A	50PN890	2011	-	
		50SW1000	50H1000	50JN1000	M940-50A	50PN1015	-	-	
		50SW1300	50H1300	50JN1300	M1100-50A	50PN1270	-	-	
	0.65	65SW400	-	-	-	65PN400	-	-	
		65SW800	-	65JN800	M800-65A	65PN890	-	M-47	
		65SW1000	-	65JN1000	M1000-65A	65PN1015	-	-	
		65SW1300	-	65JN1300	M1300-65A	65PN1270	-	-	
	High Efficient Series	0.35	35SWH250	-	-	-	-	-	
			35SWH300	-	-	-	-	-	
		0.50	50SWH470	-	50JNE470	-	-	-	-
			50SWH600	-	-	-	-	-	-
			50SWH800	-	-	-	-	-	-
	505WH1300	-	-	-	-	-	-		
Stress Relief Annealing Series	0.50	50SWR350	-	50JNA350	-	-	-		



# Regular Grade

Magnetic properties and technical characteristics of common type non-oriented electrical steel.

Grade	Thickness	Max Total Loss	Min Magnetic Polarization	Min Lamination Coefficient	Min Number of Bending	Density
	(mm)	(w/kg)		(%)		(kg/dm <sup>3</sup> )
35W230	0.35	2.10	1.62	0.95	2	7.60
35W250		2.28	1.64		2	7.60
35W270		2.45	1.64		2	7.60
35W300		2.65	1.64		2	7.65
35W360		3.20	1.65		3	7.65
35W440		3.40	1.67		3	7.70
50W250	0.50	2.30	1.64	0.97	2	7.60
50W270		2.48	1.64		2	7.60
50W290		2.65	1.64		2	7.60
50W310		2.85	1.64		2	7.60
50W350		3.00	1.65		2	7.65
50W400		3.20	1.65		5	7.65
50W470		3.30	1.70		10	7.70
50W600		4.20	1.68		10	7.75
50W700		4.70	1.70		10	7.80
50W800		5.50	1.71		10	7.80
50W1000		6.00	1.74		10	7.85
50W1300	7.00	1.74	10	7.85		
65W310	0.65	3.05	1.64	0.97	2	7.60
65W350		3.45	1.65		2	7.60
65W400		3.95	1.66		2	7.65
65W470		4.60	1.67		5	7.65
65W530		5.20	1.68		10	7.70
65W600		5.90	1.68		10	7.75
65W700		6.90	1.69		10	7.75
65W800		7.90	1.71		10	7.80
65W1000		9.90	1.71		10	7.80
65W1300		12.90	1.72		10	7.85



Magnetic properties and technical characteristics of new energy vehicle non-oriented electrical steel.

Type	Grade	Thickness	Max Total Loss	Min Magnetic Polarization	Min Lamination Coefficient	Min Number of Bending	Density
		(mm)	(w/kg)		(%)		(kg/dm <sup>3</sup> )
Common Type	20AV1200	0.20	12.00	1.61	0.93	2	7.60
	20AV1300		13.00	1.63	0.93	2	7.65
	25AV1300	0.25	13.00	1.62	0.94	2	7.60
	27AV1400	0.27	14.00	1.62	0.94	2	7.60
	30AV1500	0.30	15.00	1.63	0.94	2	7.60
	35AV1700	0.35	17.00	1.64	0.95	2	7.60
	35AV1800		18.00	1.64	0.95	2	7.60
	35AV1900		19.00	1.65	0.95	2	7.65
	35AV2000		20.00	1.65	0.95	3	7.65
	35AV2100		21.00	1.66	0.95	3	7.65
High Magnetic	20AVG1200	0.20	12.00	1.68	0.93	2	7.65
	25AVG1300	0.25	13.00	1.68	0.94	2	7.65
Induction	27AVG1400	0.27	14.00	1.68	0.94	2	7.65
	30AVG1500	0.30	15.00	1.68	0.94	2	7.65
	35AVG1700	0.35	17.00	1.68	0.95	2	7.65
	35AVG1900		19.00	1.68	0.95	3	7.65
High Efficiency	20AVX1200	0.20	12.00	1.64	0.93	2	7.65
	20AVX1300		13.00	1.65	0.93	2	7.65
	27AVX1400	0.27	14.00	1.65	0.94	2	7.65
	30AVX1500	0.30	15.00	1.66	0.94	2	7.65
	35AVX1700	0.35	17.00	1.66	0.95	2	7.65
High Strength	35AVQ500	0.35	25.00	1.64	0.95	2	7.60
	35AVQ550		32.00	1.63	0.95	2	7.60
	35AVQ600		35.00	1.60	0.95	2	7.60
High Efficiency & Strength	25AVM1300	0.25	13.00	1.65	0.94	2	7.60
	27AVM1400	0.27	14.00	1.65	0.94	2	7.60
	30AVM1500	0.30	15.00	1.65	0.94	2	7.60



Magnetic properties and technical characteristics of high efficiency non-oriented electrical steel

Type	Grade	Thickness	Max Total Loss	Min Magnetic Polarization	Min Lamination Coefficient	Min Number of Bending	Density
		(mm)	(w/kg)		(%)		kg/dm <sup>3</sup>
High Efficiency	35WG230	0.35	2.28	1.66	0.95	2	7.65
	35WG250		2.45	1.67		2	7.65
	35WG270		2.65	1.68		5	7.70
	35WG300		2.80	1.69		5	7.70
	50WG350	0.50	2.90	1.68	0.97	5	7.70
	50WG470		3.00	1.71		5	7.70
	50WG600		3.50	1.72		10	7.75
	65WG600	0.65	4.50	1.72		10	7.75

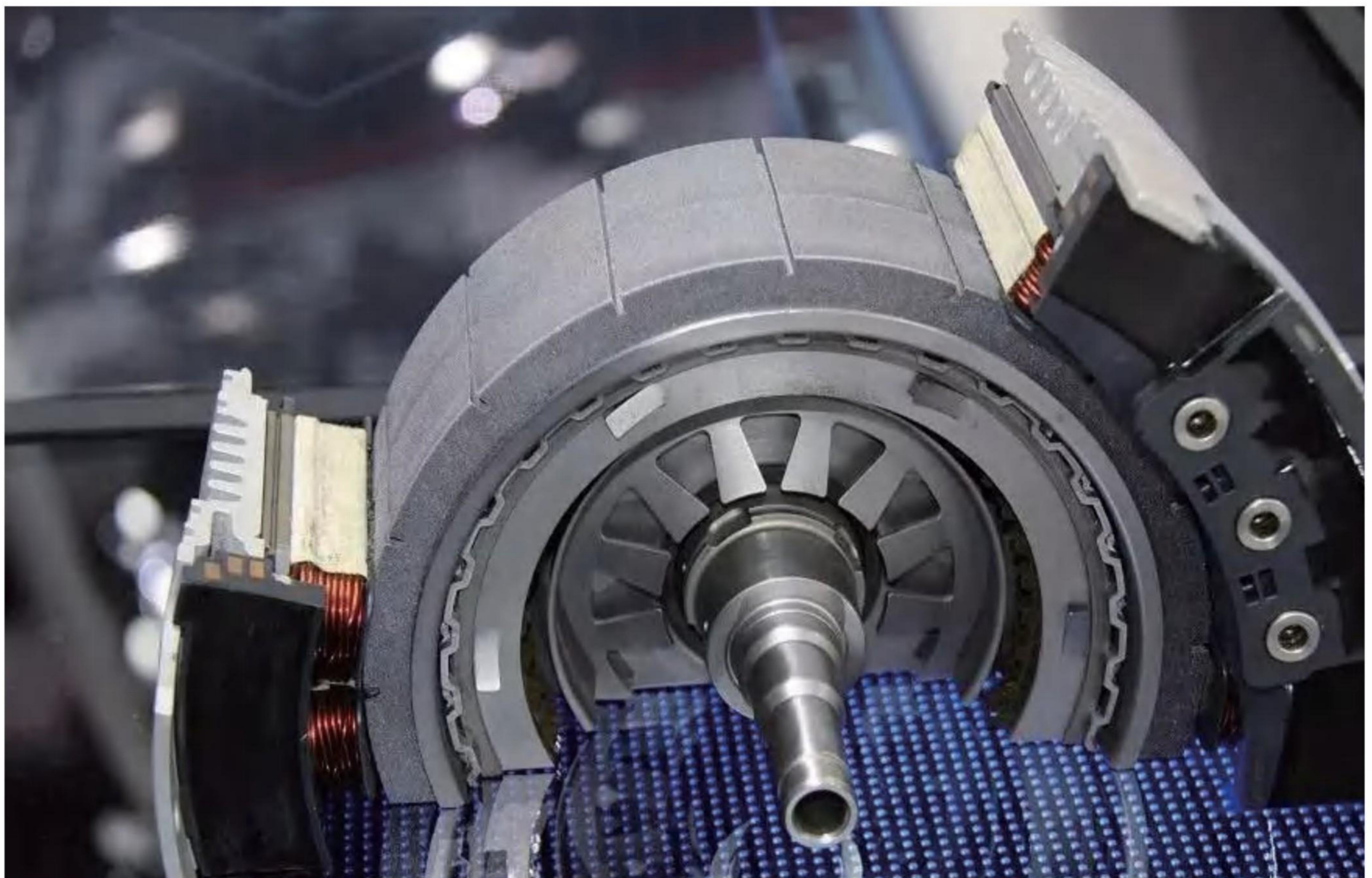



# WHY US ?

## Suppliers

---





## Horizontal Packaging

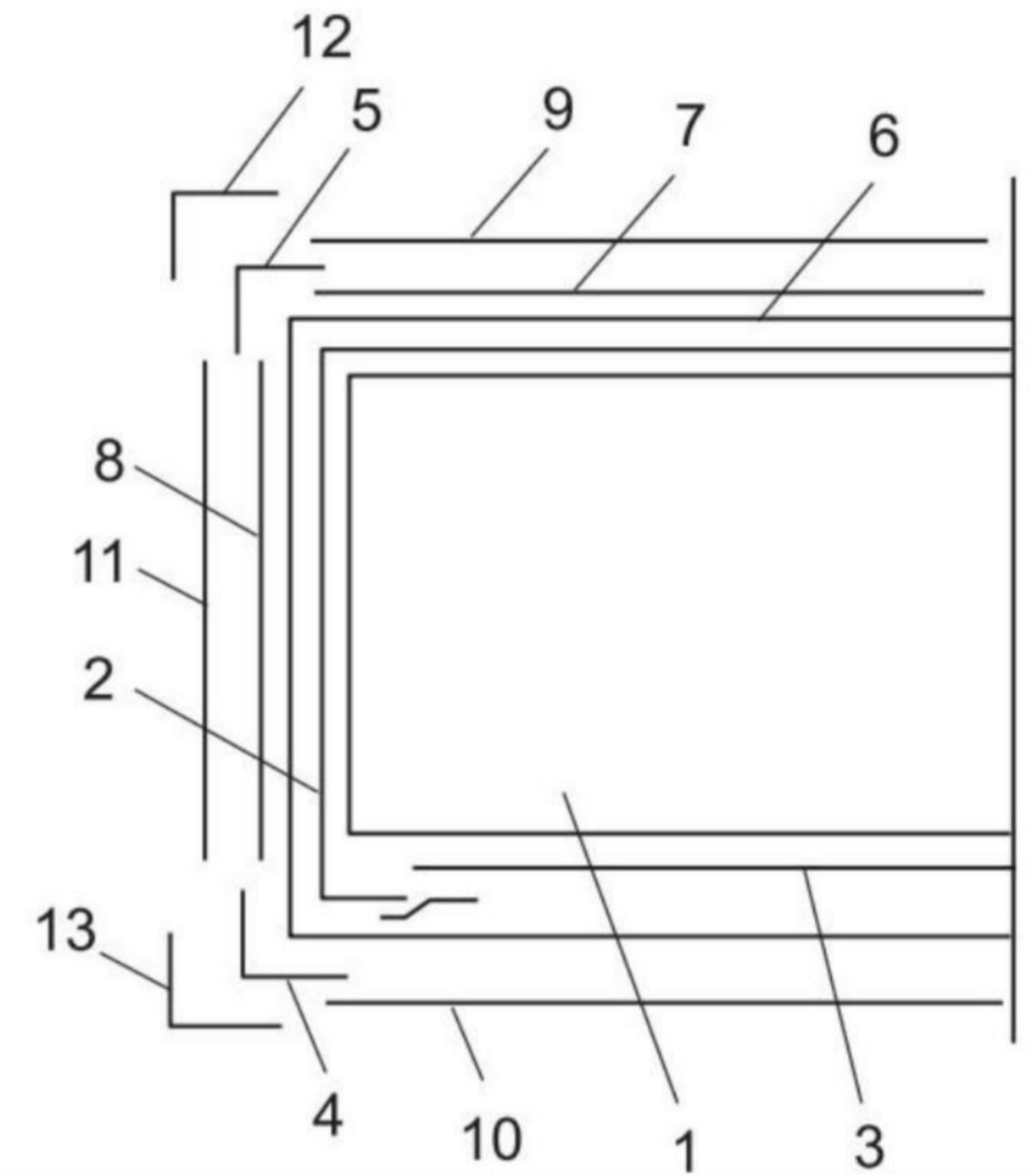
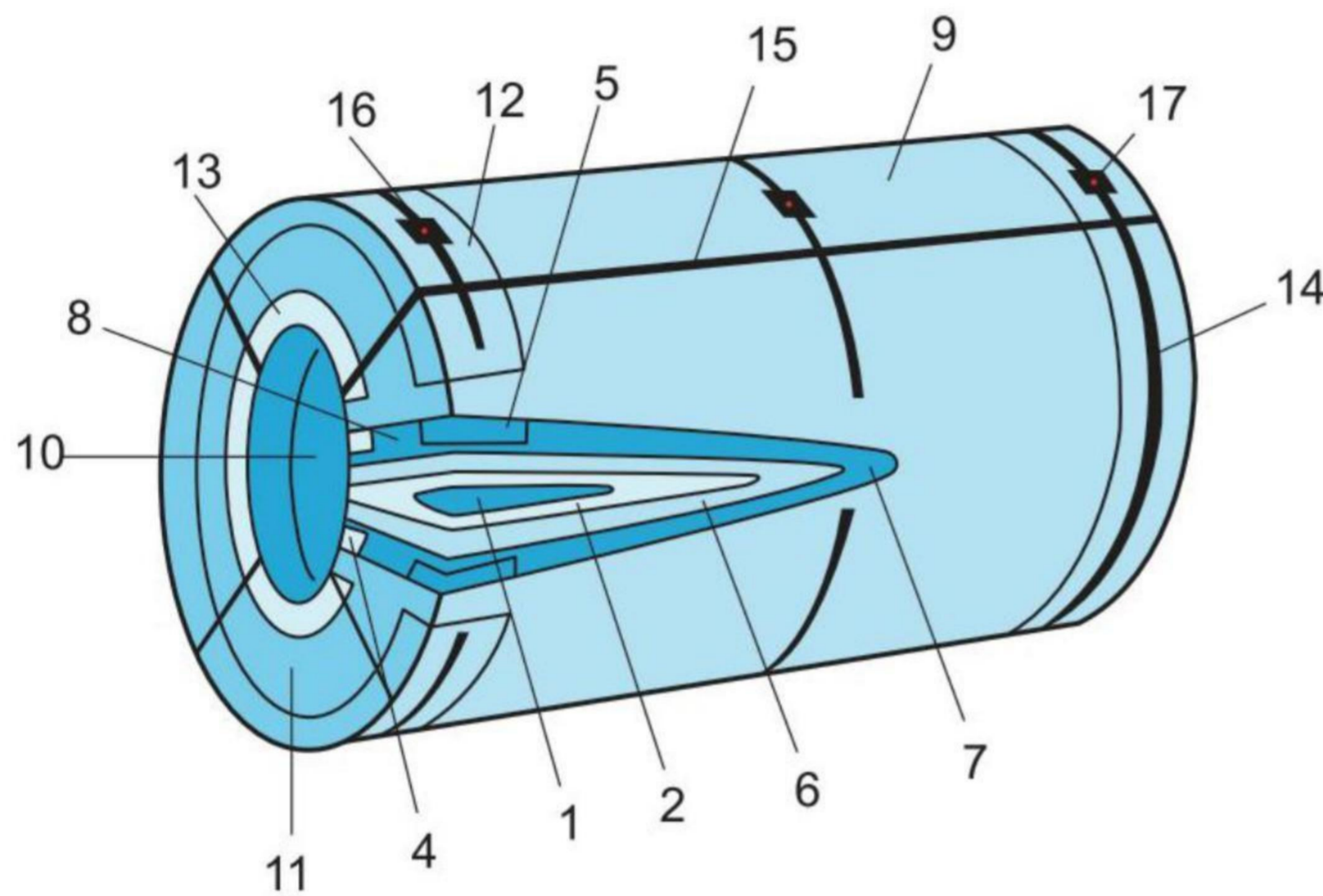

1-Steel coil

3-Peripheral anti-rust paper

5-Outer paper corner protector

7-Peripheral sheet paper

9-Peripheral protecting plate

11-End surface circular protecting plate

13-Inner iron corner protector

15-Strap in radial direction

17-Buckle

2-Peripheral anti-rust paper

4-Inner paper corner protector

6-Plastic sleeve

8-End surface circular protecting sheet paper

10-Inner circumference protecting plate

12-Outer iron corner protector

14-Strap in circumferential direction

16-Buckle shim





# Vertical Packaging

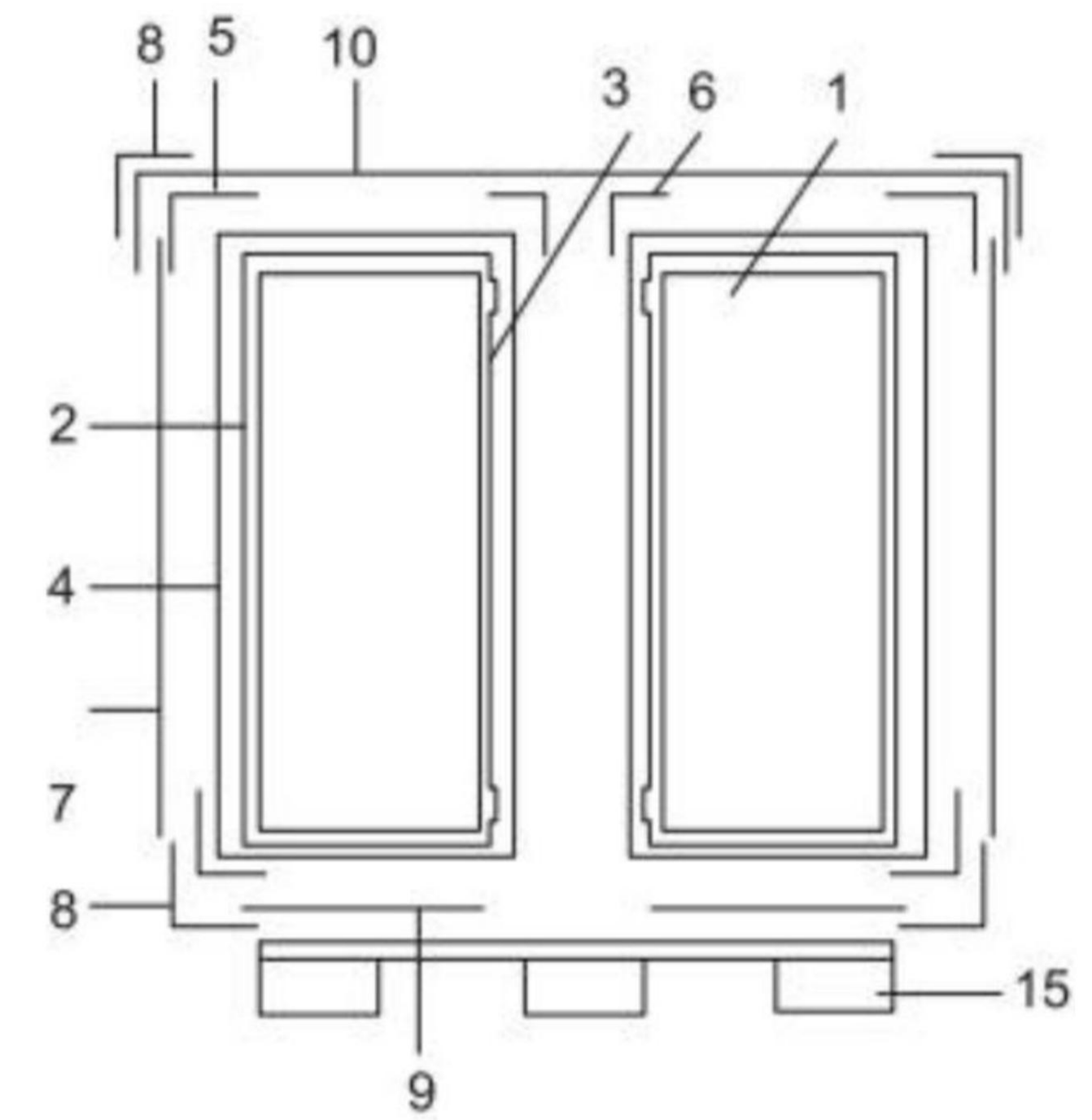
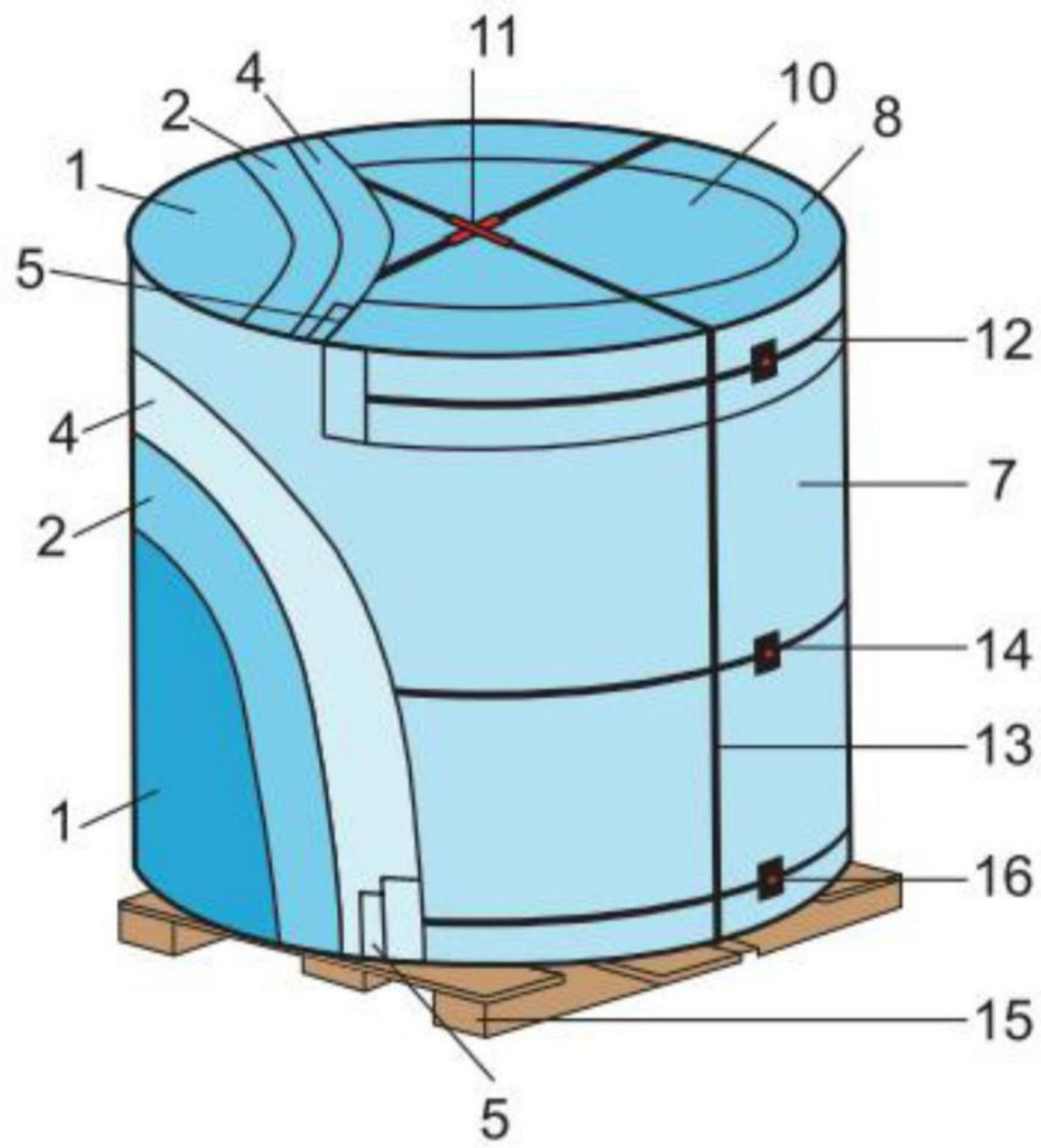

1-Steel coil

3-Inner core anti-rust paper

5-Outer paper corner protector

7-Peripheral protecting plate

9-End surface circular protecting plate

11-Cross buckle

13-Cross strap

15-Vertical wooden bracket

2-Peripheral anti-rust paper

4-Plastic sleeve

6-Inner paper corner protector

8-Outer iron corner protector

10-Circular box cap

12-Strap in circumferential direction

14-Buckle shim

16-Buckle





# Shipment

## By Container



## By Bulk

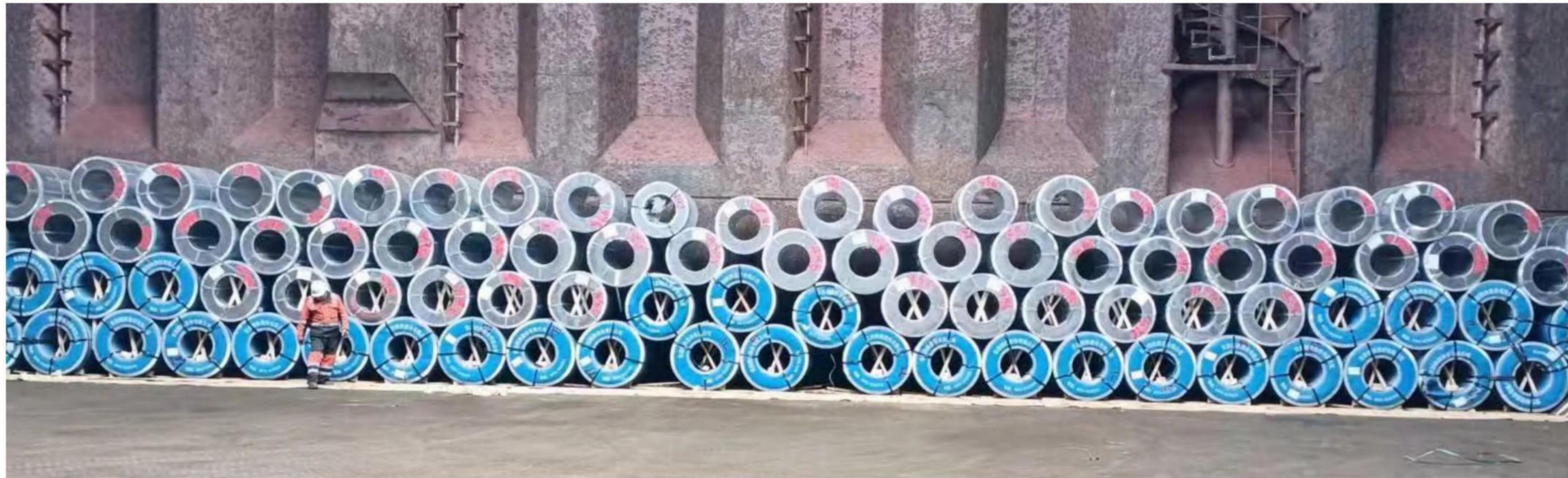



## CRGO

**宝 钢** 宝山钢铁股份有限公司  
BAOSHAN IRON & STEEL CO., LTD.

**产品质量证明书**  
INSPECTION CERTIFICATE

上海市宝山区富锦路995号 邮编 201900  
No.995 Fulin Road, BAOSHAN DISTRICT  
SHANGHAI P. R. CHINA 201900  
电话 TEL.: +86 21 26649104  
传真 FAX.: +86 21 26648886

制造商: 总部  
Manufacturer: CORE BASE

订货单位 CUSTOMER	产品名称 PRODUCT	取用电工钢带
收货单位 PURCHASER	代号 CUSTOMER DING	证书号 CERTIFICATE NO.
标准 SPECIFICATION	签订日期 DATE OF ISSUE	合同号 BILL NO.

序号 NO.	钢卷号/包号 COIL/PACK NO.	炉号 HEAT NO.	厚度 THICKNESS mm	宽度 WIDTH mm	长度 LENGTH mm	重量 WEIGHT kg	屈服强度 YIELD STRENGTH MPa	抗拉强度 TENSILE STRENGTH MPa	伸长率 ELONGATION %	厚度公差 THICKNESS TOL. mm	宽度公差 WIDTH TOL. mm	长度公差 LENGTH TOL. mm	重量公差 WEIGHT TOL. kg
合计	Total												

备注  
REMARK

注释  
NOTES

Y.S.=YIELD STRENGTH T.S.=TENSILE STRENGTH EL=ELONGATION G.L.=GAUGE LENGTH L1=30MM L2=30MM L3=5.65(QT/F2) L4=11.3(QT/F2)  
%SHEETS M.P.=MAGNETIC POLARIZATION

本产品已按上述要求制造和检验, 其检验符合要求的, 特此证明。  
WE HEREBY CERTIFY THAT MATERIAL DESCRIBED HEREIN WAS MANUFACTURED AND TESTED WITH SATISFACTORY RESULTS IN ACCORDANCE WITH THE REQUIREMENTS OF THE ABOVE SPECIFICATION.

质量负责人  
QUALITY MANAGER

**“首钢”牌产品质量证明书**  
QUALITY CERTIFICATE OF "SHOUGANG" BRAND

首钢集团地址: 中国北京市石景山区  
ADD. OF SHOUGANG GROUP: SHIJINGSHAN DISTRICT, BEIJING, CHINA  
邮政编码 POST CODE: 100041  
电话 TEL.: (010) 51706031  
制造厂地址: 中国河北省迁安市  
ADD. OF MANUFACTURER: Qian'an City Hebei Prov., China

制造商: 首钢集团: 首钢智新迁安电磁材料有限公司  
MANUFACTURER: SHOUGANG GROUP: Shougang Zhixin Qian'an Electromagnetic Material Co., LTD.

订货单位 Customer	合同编号 Contract No.	车船号 Train/Ship No.
收货单位 Purchaser	交货状态 Condition of Supply	证明编号 Certificate No.
产品名称 Product	发货日期 Date of Delivery	表号 Record No.
标准 Specification	牌号 Steel Grade	页号 Page No.

序号 No.	炉号 Heat No.	钢卷号/包号 Coil/Pack No.	厚度 Thick- ness	宽度 Width h	长度 Length L	重量 Wt. ton	*1 比总损耗 PL 5/50 W/kg	*2 屈服强度 R5000 T	*3 抗拉强度 PL 5/50 W/kg	*4 伸长率 %
合计	Total									

订单号 Order No: 80002403120007  
密度 Density kg/dm<sup>3</sup>: 7.65  
备注 Remarks:

1. 本产品经检验满足供货标准要求。  
We hereby certify that material described here in has been tested with satisfactory results in accordance with the requirements of the above material specification.  
2. 本质量证明书空白项目均不作为交货条件。  
Blank project the quality certificate are not as delivery conditions  
3. 盖章后生效。  
Sealed after the entry into force  
4. 联系方式: TEL.: 0315-7706098  
E-mail: gxs@sggc.com

日期 Date: 2024-03-22 15:37:14

质量负责人  
Person in Charge of Quality Inspection

## CRNGO

**“首钢”牌产品质量证明书**  
QUALITY CERTIFICATE OF "SHOUGANG" BRAND

首钢集团地址: 中国北京市石景山区  
ADD. OF SHOUGANG GROUP: SHIJINGSHAN DISTRICT, BEIJING, CHINA  
邮政编码 POST CODE: 100041  
电话 TEL.: (010) 51706031  
制造厂地址: 中国河北省迁安市  
ADD. OF MANUFACTURER: Qian'an City Hebei Prov., China

制造商: 首钢集团: 首钢智新迁安电磁材料有限公司  
MANUFACTURER: SHOUGANG GROUP: Shougang Zhixin Qian'an Electromagnetic Material Co., LTD.

订货单位 Customer	合同编号 Contract No.	车船号 Train/Ship No.
收货单位 Purchaser	交货状态 Condition of Supply	证明编号 Certificate No.
产品名称 Product	发货日期 Date of Delivery	表号 Record No.
标准 Specification	牌号 Steel Grade	页号 Page No.

序号 No.	炉号 Heat No.	钢卷号/包号 Coil/Pack No.	厚度 Thick- ness	宽度 Width h	长度 Length L	重量 Wt. ton	*1 比总损耗 PL 5/50 W/kg	*2 屈服强度 R5000 T	*3 抗拉强度 PL 5/50 W/kg	*4 伸长率 %
合计	Total									

备注 Remarks

密度 Density kg/dm<sup>3</sup>: 7.8  
订单号 Order No: 80002212300016

1. 本产品经检验满足供货标准要求。  
We hereby certify that material described here in has been tested with satisfactory results in accordance with the requirements of the above material specification.  
2. 本质量证明书空白项目均不作为交货条件。  
Blank project the quality certificate are not as delivery conditions  
3. 盖章后生效。  
Sealed after the entry into force  
4. 联系方式: TEL.: 0315-7706098  
E-mail: gxs@sggc.com

日期 Date: 2023-02-04

质量负责人  
Person in Charge of Quality Inspection

**“首钢”牌产品质量证明书**  
QUALITY CERTIFICATE OF "SHOUGANG" BRAND

首钢集团地址: 中国北京市石景山区  
ADD. OF SHOUGANG GROUP: SHIJINGSHAN DISTRICT, BEIJING, CHINA  
邮政编码 POST CODE: 100041  
电话 TEL.: (010) 51706031  
制造厂地址: 中国河北省迁安市  
ADD. OF MANUFACTURER: Qian'an City Hebei Prov., China

制造商: 首钢集团: 首钢智新迁安电磁材料有限公司  
MANUFACTURER: SHOUGANG GROUP: Shougang Zhixin Qian'an Electromagnetic Material Co., LTD.

订货单位 Customer	合同编号 Contract No.	车船号 Train/Ship No.
收货单位 Purchaser	交货状态 Condition of Supply	证明编号 Certificate No.
产品名称 Product	发货日期 Date of Delivery	表号 Record No.
标准 Specification	牌号 Steel Grade	页号 Page No.

序号 No.	炉号 Heat No.	钢卷号/包号 Coil/Pack No.	厚度 Thick- ness	宽度 Width h	长度 Length L	重量 Wt. ton	*1 比总损耗 PL 5/50 W/kg	*2 屈服强度 R5000 T	*3 抗拉强度 PL 5/50 W/kg	*4 伸长率 %
合计	Total									

备注 Remarks

密度 Density kg/dm<sup>3</sup>: 7.75  
订单号 Order No: 8000230540003

1. 本产品经检验满足供货标准要求。  
We hereby certify that material described here in has been tested with satisfactory results in accordance with the requirements of the above material specification.  
2. 本质量证明书空白项目均不作为交货条件。  
Blank project the quality certificate are not as delivery conditions  
3. 盖章后生效。  
Sealed after the entry into force  
4. 联系方式: TEL.: 0315-7706098  
E-mail: gxs@sggc.com

日期 Date: 2023-05-14

质量负责人  
Person in Charge of Quality Inspection







☎ Tel: 0086 22 6565 7971

☎ Mob: 0086 155 1008 0821

✉ Email: [info@steelhighsen.com](mailto:info@steelhighsen.com)    🌐 Website: [www.steelhighsen.com](http://www.steelhighsen.com)

📍 Add: Room 805, Unit 1, Building 6, Ronghe Plaza, Airport Economic Area, Tianjin, China